

DATC

-Dual Automatic Temperature Control -



General Specification

Item	Tuscan (JM)	LM
Compressor	Internal variable capacity swash plate type (10PA17/10PA19)	External variable capacity swash plate type (DVE16)
Cluster ionizer	Not applied	Applied
Fin thermo sensor	Evaporator core insertion type	Air detection type (Surface temp. detection)
Full automatic air conditioning (DATC)	External temp. sensor and AQS sensor separable	External temp. sensor (AQS sensor removed)
	Interior temp. sensor and humidity sensor combined (ACTIVE MOTOR TYPE)	Independent type (Humidity sensor removed) (Aspirator type)
	Independent type	Photo sensor and solar radiation sensor combined (Dual solar radiation sensor applied)
	Coolant temp. sensor applied	Coolant temp. sensor not applied (Engine coolant temp. sensor shared)
	Temp. actuator (F/B type)	F/B type (Built-in position sensor)
	Mode actuator (F/B type)	F/B type (Built-in position sensor)
	Intake actuator	F/B type (Built-in position sensor)

Construction

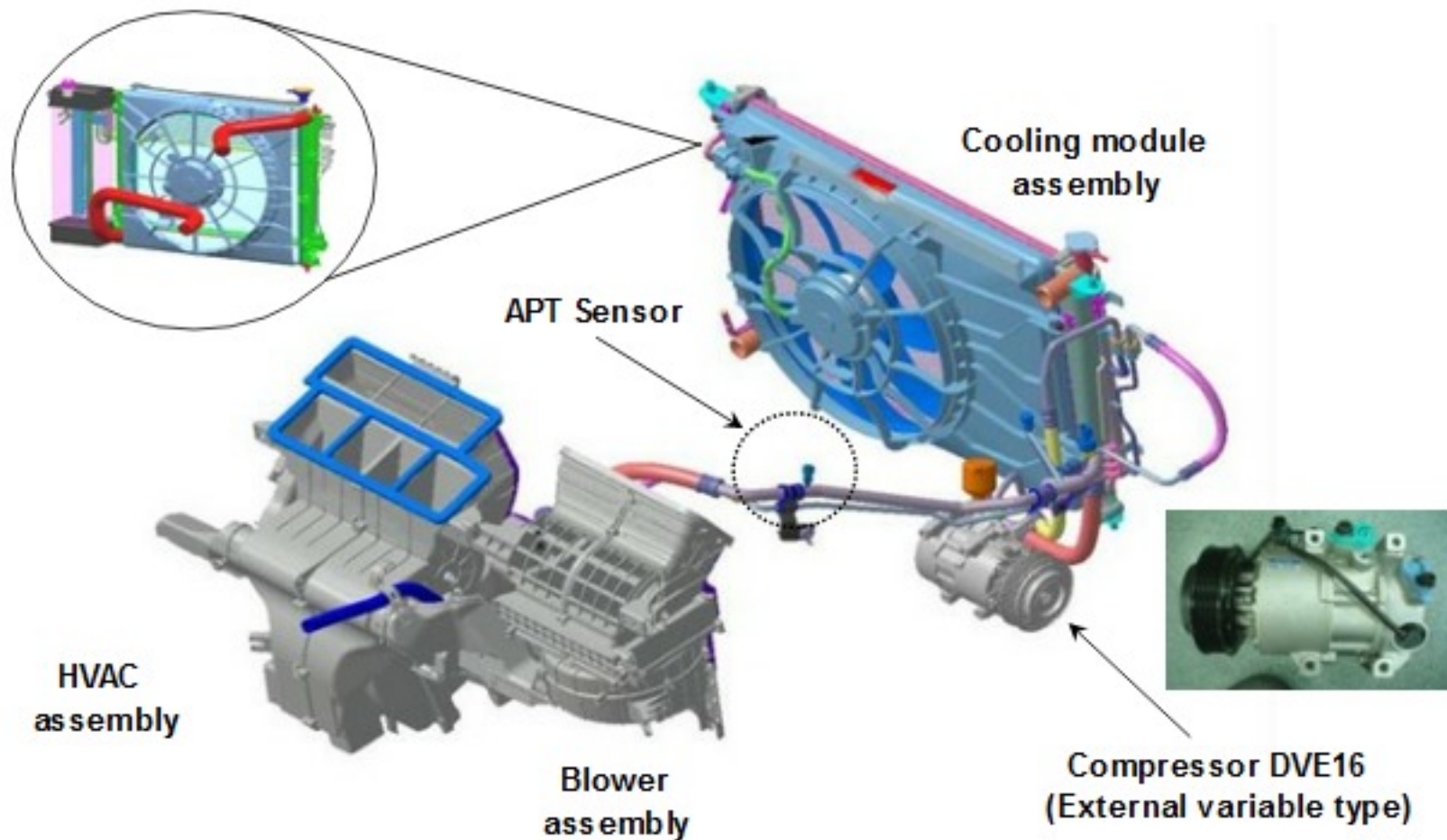

Components

HVAC (Heating Ventilation Air Conditioning)

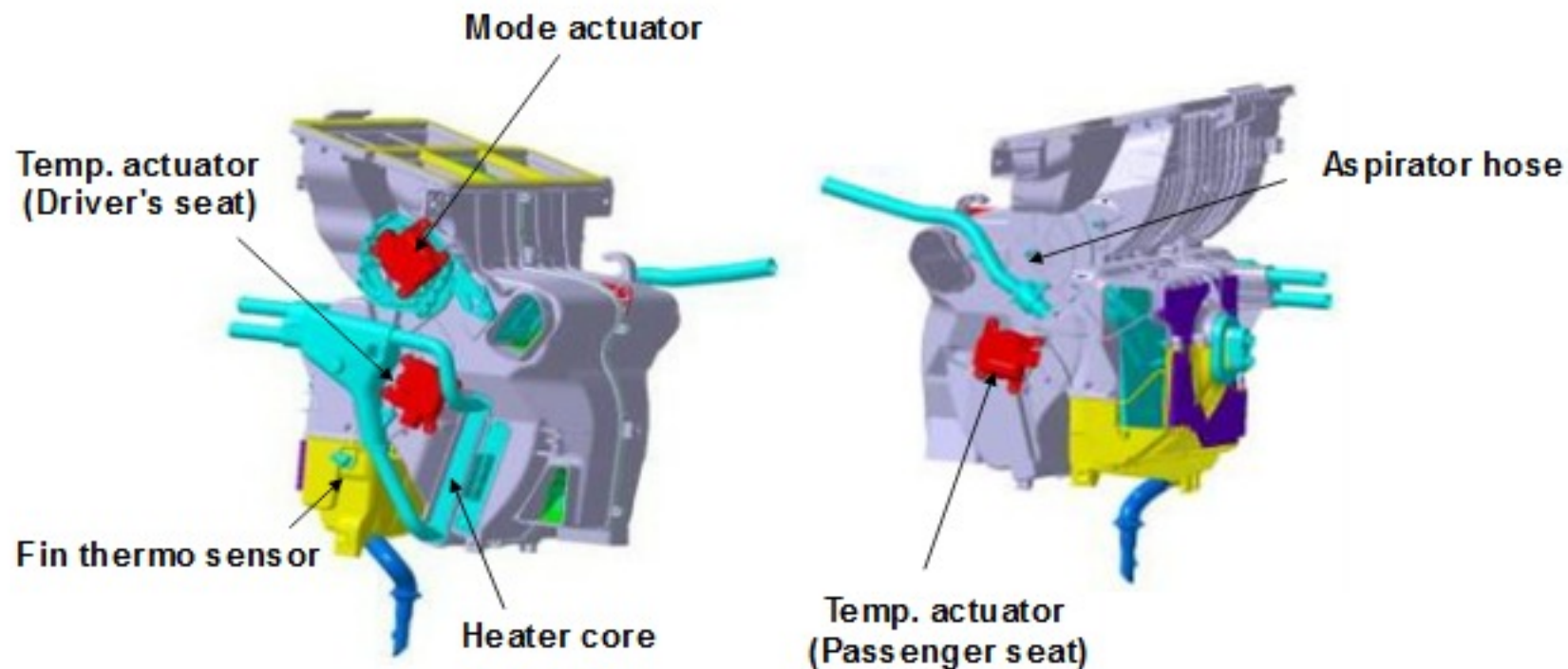

Components

Blower assembly

Interior/Exterior air actuator

Cluster ionizer

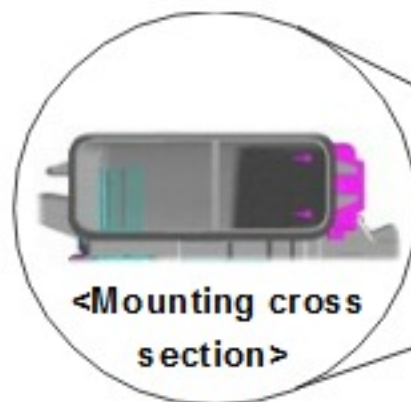

Air filter cover
(Filter separation type)

Blower motor

Cation generation part

Anion generation part

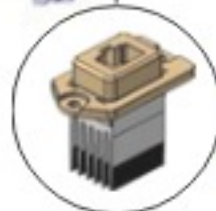

FET

(Resistor is used for the manual air conditioning system)

※Cluster ionizer is applied only to the DATC air conditioning.

Inputs & Outputs

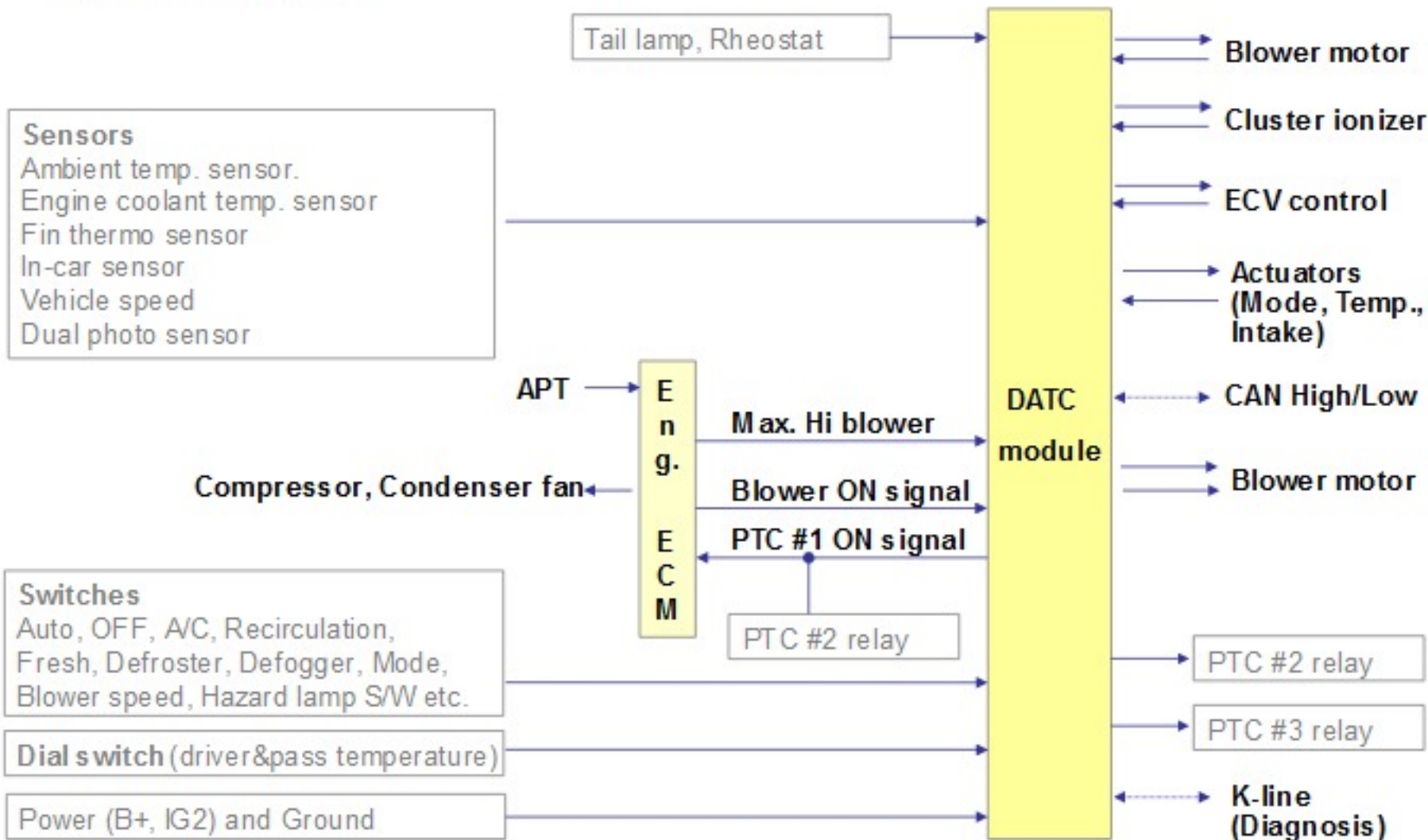

Cluster ionizer

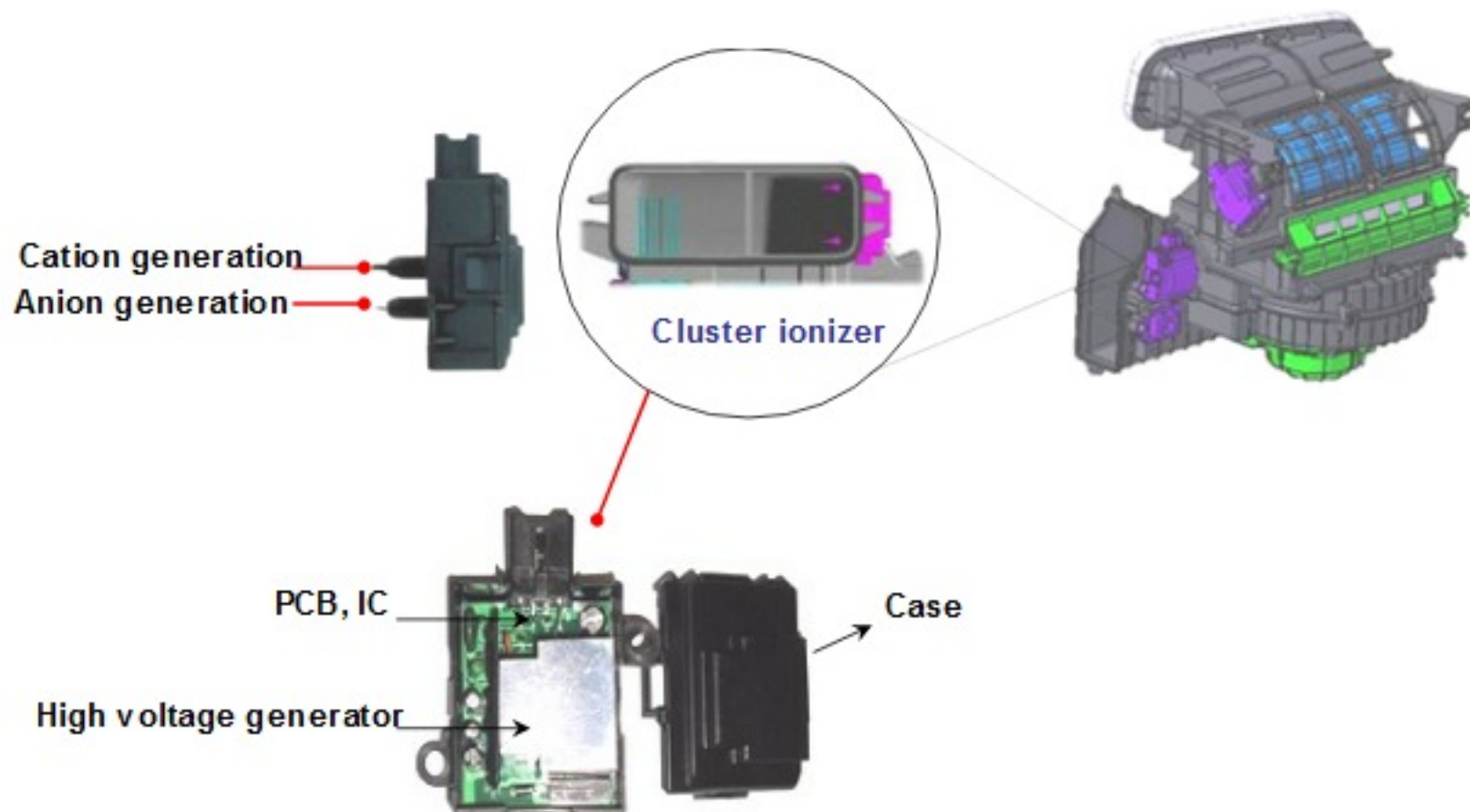

Cluster ionizer

Cluster ionizer mode

Signals	Ion mode	Clean mode	OFF
	(-) ion activation	(+,-) ion activation	
ION signal	HI (12V)	LOW (0V)	LOW (0V)
CLEAN signal	HI (12V)	HI (12V)	LOW (0V)

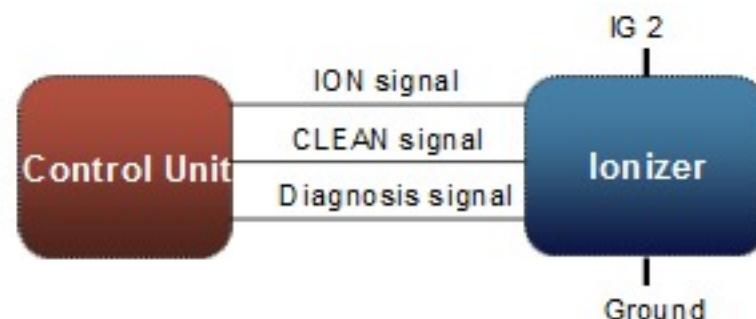

Cluster ionizer operating lamp

- CLEAN mode : CLEAN display
- ION mode : ION display

Variable Swash Plate Compressor

With Mechanical Control Valve (DV)

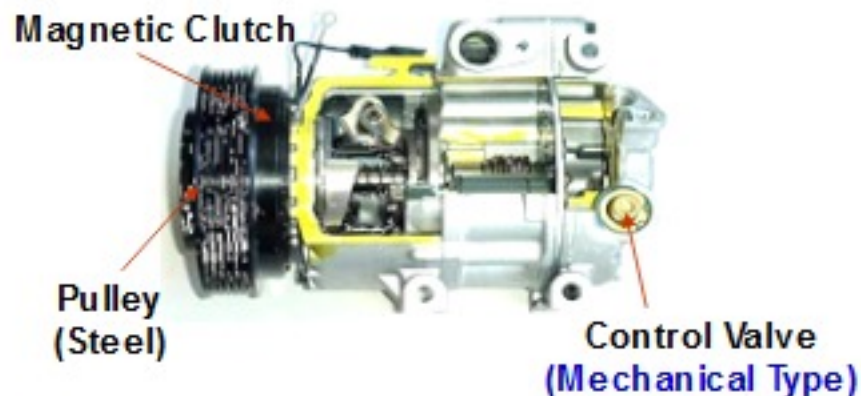

With Electric Control Valve (DVE)



Section	DV	VSX
Control Valve	Mechanical Control Valve	Electric Control Valve
Magnetic clutch	Adopted	Non
Outlet Temp. control	Variable control	Variable control in detail
Applied Model	NF, TG, HD, FD, FC etc	BH, VI

Electric Control Valve

A/C OFF Mode Control

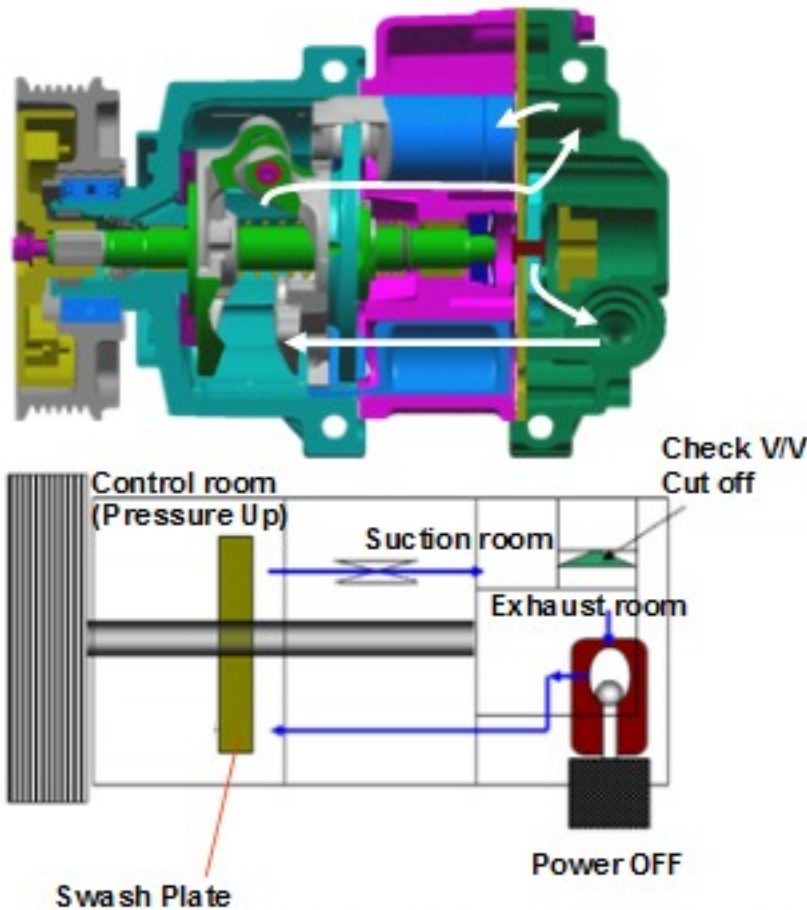

A/C ON & Variable Control

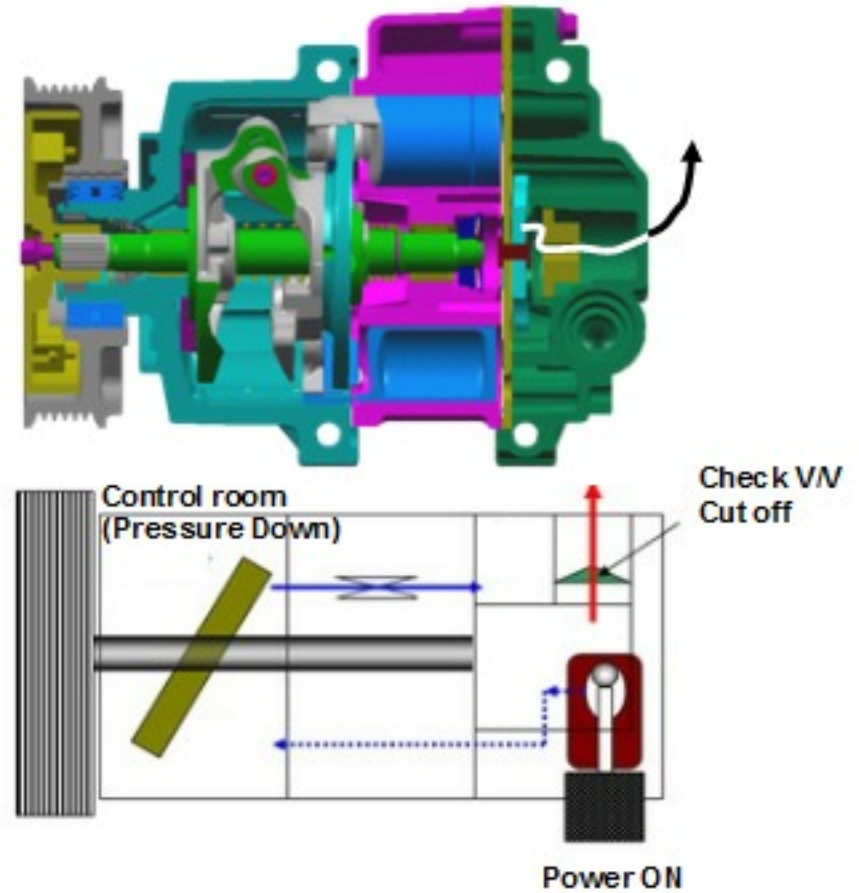

Control Block Diagram

- A/C relay ON signal
- ENG rpm
- Vehicle speed
- Coolant temp.
- APT value
- Max torque limited
- A/C output signal
- Calculate torque signal
- Max blower speed
- Blower ON signal
- ECV fault

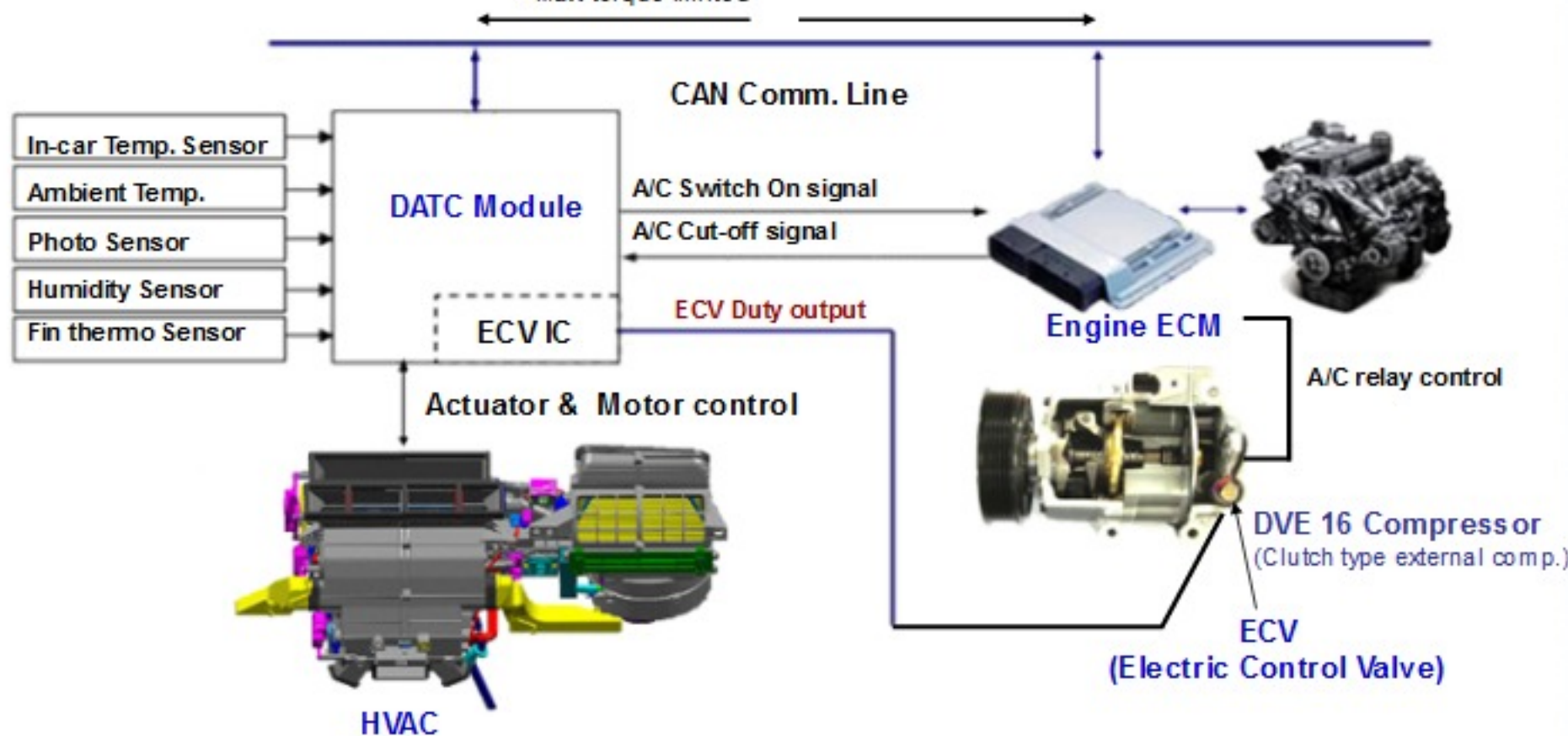

Owner's setting procedure

Defrost logic setting



1. Defroster button
2. Push and hold A/C button + push intake button 5 times in 3 seconds
3. Check the display screen (3 times blinking)

Temperature unit conversion



1. OFF button + AUTO button (5sec)

Owner's setting procedure

Self diagnosis (Using the control panel)



1. Push MODE button while pushing OFF (4times within 2 sec)
2. Blinking all display (2times, 2Hz)
3. Check the DTC on display

Refrigerant Filling

After the compressor (part) replacement or refrigerant discharge

Refrigerant injection

Initial A/C operation

After pre-run

*Idling
for 3 min or more !!*

Pre-Run

